

Rubber Non-Skid Pad

35-9872

37-8660

K&L MC455 FAT JACK

Everything you like about the MC450 and more. Fat Jack's wider deck with rubber non-skid pad increases your lifting area for increased stability with the reliability of K&L engineering. Minimum Height: 3-1/2", Maximum Height: 13" UPS shippable. Dimensions: 16" (405mm) length x 5-1/2" (135mm) width. Maximum Height: 13" (330mm). Base width: 14" (355mm)

37-8660 MC455 Fat Jack-Zinc



37-9885

35-9872

K&L MC550 MULTI-LIFT

Multi lift jack works with most motorcycles. Minimum height: 4.5", Maximum Height: 17." Available in powder coated blue or red. Features include:

- 1.5" square tubing
- 16" padded contact area
- Foot operated locks
- 4 ton bottle jack
- Locking caster wheels
- Foot operated valve
- Tie down points provided

37-9885 Multi-lift, Blue 37-9906 Multi-lift, Red

37-8623 Replacement 4 ton Bottle Jack



LOW RIDING RAMP

Constructed from .125" thick Diamond plate metal, this ramp will raise the front or rear wheel 3". The bottom of ramp features rubber footing to ensure a positive grip. This ramp is essential when using K&L Dyna-Glide® Adapter (35-0806), to get proper height clearance, and also helps when lifting a lowered Softail® up onto our K&L multi-lift.

35-0808 Low Riding Ramp with built in handle

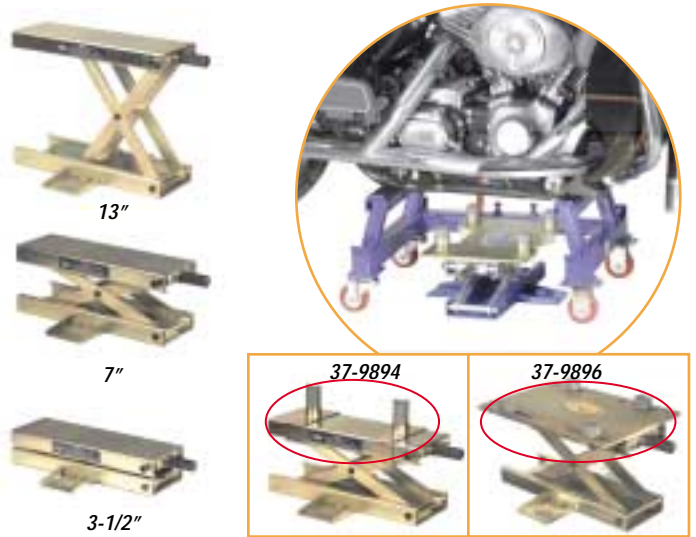

K&L MC450 CENTER JACK

This easy to use scissor jack is the answer for raising bikes. Lift front or rear of bikes that are on MC600 type lifts. Add the adapter kits for more flexibility. UPS shippable.

Height: 3-1/2", Maximum Height: 13". Dimensions: 16" (405mm) length x 5-1/2" (135mm) width. Maximum Height: 13" (330mm). Base width: 14" (355mm)

37-9841 MC450 Center Jack

OPTIONAL ADAPTERS

37-9896 Adapter Plate --This plate mounts onto the MC450 and features 4 adjustable frame contact points. Fit's MC450's mfg. 1999 on.

37-9894 Adapter Post Kit--Provides for width and height adjustment. Kit includes 1.5" and 3" posts. Fit's MC450's mfg. 1999 on.

37-9134 MC450 Repair Kit--Fit's MC450's mfg.1999 on.

37-9135 MC450 Retro Fit Repair Kit--Fit's MC450's mfg. before 1999.

K&L MC460 SHOP DOLLY

This dolly allows bikes to be easily moved. Works with MC450 and MC550 Multi-Lift center stand and similar type jacks. Features include:

- Adjustable width from 13" to 20" at base
- 12" to 15" Adjustable height.
- Swivel neoprene wheels
- Four tie down attachment points and rubber pads at frame contact points.

35-9872 Shop Dolly, Blue 35-9996 Shop Dolly, Red



MC550 MULTI-LIFT ADAPTER FOR SPORTSTER®

This adapter allows clearance for the tight confines found between Sportster® frame rails and exhaust.

35-0786 Sportster® Lift Adapter

MC550 MULTI-LIFT ADAPTER FOR DYNA®

This adapter gives you the clearance needed when lifting a Harley-Davidson® Twin-Cam Dyna-Glide® up onto MC550 Multi-Lift.

35-0806 Dyna® Lift Adapter